

ELECTRIC RIDERS

Cushion Tire Lift Trucks Electric 36/48 Volt

ECX20
ECX25
ECX30
ECX32

4,000 lbs 2000 kg
5,000 lbs 2500 kg
6,000 lbs 3000 kg
6,500 lbs 3000 kg



ECX20/25/30/32



CLARK[®]
BUILT TO LAST.[®]

w w w . c l a r k m h c . c o m

For corresponding data see Specification Chart.

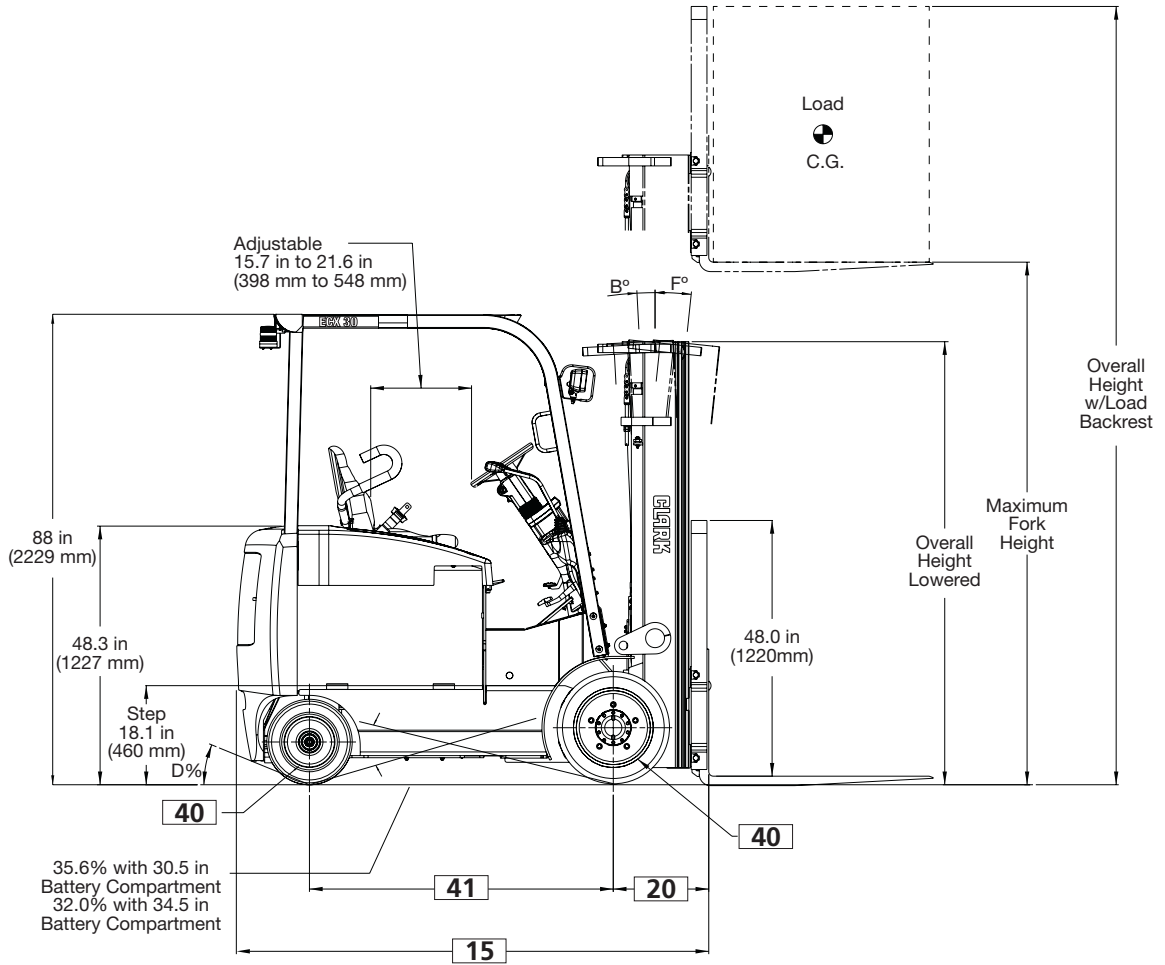

ECX20/25/30/32

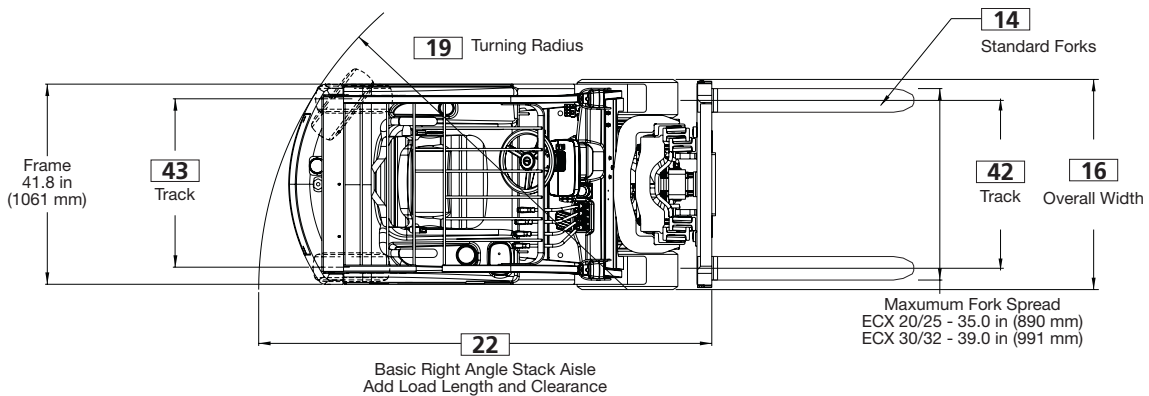

Upright Table

Maximum Fork Height		Overall Height Lowered		Free Lift w/o LBR		Std. Tilt B°/F°
in	mm	in	mm	in	mm	
Standard Two Stage						
ECX 20/25/30						
83	2120	60	1525	4	110	8/8
106	2680	71	1805	4	110	8/8
117	2980	77	1955	4	110	8/8
• 130	3300	83	2115	4	110	8/8
146	3725	95	2405	4	110	8/8
152	3860	98	2480	4	110	5/6
164	4165	108	2750	4	110	5/6
172	4380	116	2950	4	110	5/6
182	4620	125	3180	4	110	5/6
203	5170	136	3445	4	110	5/3

ECX 32						
• 128	3250	83	2115	4.5	115	8/8
144	3650	95	2405	4.5	115	8/8

HI-Lo Two Stage						
ECX 20/25						
115	2935	77	1955	55	1402	8/8
• 128	3255	83	2115	61.5	1562	8/8
139	3530	89	2255	67	1702	8/8
148	3760	95	2405	73	1852	8/8
154	3910	98	2480	76	1927	5/6

ECX 30						
115	2935	77	1955	53	1342	8/8
• 128	3255	83.3	2115	59	1502	8/8
139	3530	88.8	2255	64.6	1642	8/8
148	3760	94.7	2405	70.6	1792	8/8
154	3910	97.6	2480	73.5	1867	5/6

Triple Stage						
ECX 20/25/30						
152	3860	71	1805	49	1252	5/6
170	4320	77	1955	55	1402	5/6
• 189	4800	83	2115	61.5	1562	5/6
205	5210	89	2255	67	1702	5/3
217	5520	95	2405	73	1852	5/3
226	5740	97.6	2480	76	1927	5/3
240	6100	104	2640	82	2087	5/3
251	6370	108	2750	86.5	2197	3/0
269	6830	116	2950	94.4	2397	3/0
288	7315	125	3180	103.4	2627	3/0

ECX 32						
146	3700	71	1805	45	1146	8/8
164	4160	77	1955	51	1296	5/6
• 189	4800	85	2170	59	1511	5/6
199	5050	89	2255	63	1596	5/3
211	5360	95	2405	69	1746	5/3

Quad Four Stage						
All Models						
216	5486	77	1956	52	1321	5/3
• 240	6096	83	2108	58	1473	5/3
258	6553	89	2261	64	1626	5/0

- Indicates preferred standard sizes. For overall height raised with load backrest, add 48 in. (1220 mm) to maximum fork height. Other uprights available, contact a CLARK representative.

** All free lift dimensions shown without standard 48 in. (1220 mm) high load backrest.

Available Equipment

- Unitrol™, foot operated direction control
- Cold storage specifications
- Suspension seat
- Various lights, audible alarms & mirrors
- UL EE classification

Contact your CLARK representative for availability of unlisted options.

Battery Compartment Dimensions

Width (W)		Length (L)		Height (H)	
in	mm	in	mm	in	mm
ECX 20/25/30					
39.25	997	30.5	775	23.5	597
ECX 32 (available option on ECX 20/25/30)					
39.25	997	34.5	876	23.5	597

Battery without cover, termination: A-18", Connector: 6320 (SB 350 Gray)

Specifications With Optional Battery Compartment

ECX 20		ECX 25		ECX 30	
in	mm	in	mm	in	mm
Length to Fork Face					
86.8	2206	87.9	2233	90.2	2292
Turning Radius					
74.2	1885	74.8	1901	76.7	1948
Right Angle Stack Aisle					
90.9	2309	91.9	2335	94.1	2390
lbs	kgs	lbs	kgs	lbs	kgs

Service Weight, TSU upright					
9811	4450	10307	4675	11122	5045
Axle Loading w/ Load, Front					
11918	5406	13636	6185	15373	6973
Axle Loading w/ Load, Rear					
1892	858	1671	758	1748	793
Axle Loading w/o Load, Front					
4877	2212	4833	2192	4786	2171
Axle Loading w/o Load, Rear					
4934	2238	5474	2483	6336	2874
Battery Weight, Minimum					
3000	1361	3000	1361	3000	1361

Maximum Capacity (6 hour rating) Kwh					
48.6		48.6		48.6	
Grade Clearance (D%)					
62%		57%		45%	

Notes

Performance may vary +5% and -10% due to motor and system efficiency tolerance. The performance shown represents nominal values which may be obtained under typical operating conditions of a standard machine.

CLARK products and specifications are subject to change without notice. © CLARK Material Handling Company 2006.

ANSI/ASME and Insurance Classification

Standard truck meets all applicable mandatory requirements of ASME-B56.1 Safety Standard for Powered Industrial Trucks and Underwriters Laboratories requirements as to fire and electrical shock hazard only for "E" classification. For further information contact a CLARK representative.

For Your Safety

Before operating a lift truck, an operator must:

- Be trained and authorized
- Read and understand the operator's manual
- Not operate a faulty lift truck
- Not repair a lift truck unless trained and authorized
- Have the overhead guard and load backrest extension in place

During operation, a lift truck operator must:

- Wear a seat belt
- Keep entire body inside truck cab
- Never carry passengers or lift people
- Keep truck away from people and obstructions
- Travel with lift mechanism as low as possible and tilted back

To park a lift truck, an operator must:

- Completely lower forks or attachments
- Shift into neutral
- Turn key off
- Set parking brake

Contact your CLARK dealer for operator training information.

General Information	1	Manufacturer		Clark	Clark	
	2	Model	Manufacturer's Designation	ECX 20	ECX 25	
	3	Load Capacity		lb(kg)	4,000 (2000)	5,000 (2500)
	4	Load Center	Fork Face to Load CG	in(mm)	24 (500)	24 (500)
	5	Power Unit	Electric		36V 48V	36V 48V
	6	Operator Type			Rider - Counterbalanced	Rider - Counterbalanced
	7	Tire Type			Cushion Electric Compound	Cushion Electric Compound
	8	Wheels (X=Driven)	Front/Rear		2X/2	2X/2
Basic Dimensions ¹	9	Upright ¹	Maximum Fork Height, Full Capacity	in(mm)	189 (4800)	189 (4800)
	10		Lift Height (Preferred Triple Stage)	in(mm)	189 (4800)	189 (4800)
	11		Free Lift, Triple Stage	in(mm)	58.5 (1486)	58.5 (1486)
	12	Upright Tilt	Back/Forward, (See Tilt Specifications)	deg	5/6	5/6
	14	Fork	Std. Fork Size (T X W X L)	in(mm)	1.5x4x42 (40X100X1067)	1.5x4x42 (40X100X1067)
	15	Overall Dimensions	Length to Fork Face	in(mm)	82.8 (2104)	86.2 (2190)
	16		Width (Std. Tires) ³	in(mm)	41.9 (1063)	43.9 (1114)
	17		Height, Upright Lowered	in(mm)	88 (2235)	88 (2235)
	18		Height, Upright Extended (LBR)	in(mm)	237 (6020)	237 (6020)
	19	Turning Radius	Outside	in(mm)	70.2 (1783)	72.6 (1845)
	20	Load Center Distance	Center of Drive Axle to Fork Face	in(mm)	16.7 (424)	16.7 (424)
	22	Right Angle Stack Aisle	Add Load Length and Clearance	in(mm)	86.8 (2204)	89.7 (2279)
Performance ²	23	Stability	According to ANSI		Yes	Yes
	24	Travel Speeds, Loaded	With Max Load	mph (km/h)	8.8 (14.2) 10.8 (17.4)	8.5 (13.7) 10.6 (17.1)
	25	Travel Speeds, Empty	With No Load	mph (km/h)	9.2 (14.8) 11.3 (18.2)	9.1 (14.6) 11.0 (17.7)
	26	Lift Speeds, Loaded	Triple Stage	fpm (m/s)	59 (0.30) 96 (0.49)	55 (0.28) 90 (0.46)
		Lift Speeds, Empty	Triple Stage	fpm (m/s)	100 (0.51) 114 (0.58)	100 (0.51) 114 (0.58)
	27	Lower Speeds, Loaded	Triple Stage	fpm (m/s)	88 (0.45)	90 (0.46)
		Lower Speeds, Empty	Triple Stage	fpm (m/s)	80 (0.41)	80 (0.41)
Weights ³	34	Service Weight	Min Battery Weight, 30.5 in compartment	lb(kg)	9348 (4240)	10582 (4800)
	35	Axle Loading	With Load, Front	lb(kg)	11810 (5357)	13422 (6088)
			With Load, Rear	lb(kg)	1537 (697)	2161 (980)
	36		W/O Load, Front	lb(kg)	4766 (2162)	4621 (2096)
	37		W/O Load, Rear	lb(kg)	4581 (2078)	5961 (2704)
	38					
Chassis	39	Tires	Number, Front/Rear		2/2	2/2
	40		Size, Front	in(mm)	21X7X15 (533x178x381)	21X8X15 (533x203x381)
			Size, Rear	in(mm)	16X6X10.5 (406x152x267)	16X6X10.5 (406x152x267)
	41	Wheelbase		in(mm)	53 (1346)	53 (1346)
	42	Track	Front Cushion	in(mm)	34.8 (884)	35.8 (909)
	43		Rear Cushion	in(mm)	34.2 (869)	34.2 (869)
	44	Ground Clearance	Min. w/o Load	in(mm)	2.8 (71)	2.8 (71)
	45		At Center of Wheelbase	in(mm)	4.5 (114)	4.5 (114)
	46	Brakes	Service		Drum and Shoe	Drum and Shoe
	47		Parking		Pedal Actuated	Pedal Actuated
		Steering		Hydrostatic	Hydrostatic	
Drive Line	48	Battery	Type		Lead-acid	Lead-acid
			Max Capacity (6hr. Rate) 30.5 in comp	kwh	41.8	41.8
			Weight, Min	lb(kg)	2600 (1180)	2600 (1180)
	49	Motors, Controls	Drive Motor, Diameter	in(mm)	10.6 (270)	10.6 (270)
	50		Hydraulic Motor, Diameter	in(mm)	7.9 (200)	7.9 (200)
	51		Drive Motor Control		Mosfet Inverter	Mosfet Inverter
	52		Speed Control		Solid State	Solid State
	53		Hydraulic Motor Control		Mosfet Inverter	Mosfet Inverter
	54					
	55					
	57	Hydraulic Pressure	For Attachments	psi(bar)	Adjustable	Adjustable
		Grade Clearance (D%)		(%)	62%	45%

Notes: 1 See Upright Table.

2 Specifications are given with Triple Stage upright, standard battery compartment size and minimum battery weight

3 OAW with wide drive tires is 48.7 for all models; required with all quad uprights and with triple uprights above 240 inches.

4 Standard compartment size on ECX 32 model is 34.5" (876 mm).

General Information	1	Manufacturer		Clark	Clark		
	2	Model	Manufacturer's Designation	ECX 30	ECX 32		
	3	Load Capacity		lb(kg)	6,000 (3000)	6,500 (3000)	
	4	Load Center	Fork Face to Load CG	in(mm)	24 (500)	24 (500)	
	5	Power Unit	Electric		36V 48V	36V 48V	
	6	Operator Type			Rider - Counterbalanced	Rider - Counterbalanced	
	7	Tire Type			Cushion Electric Compound	Cushion Electric Compound	
	8	Wheels (X=Driven)	Front/Rear		2X/2	2X/2	
Basic Dimensions ¹	9	Upright ¹	Maximum Fork Height, Full Capacity	in(mm)	170 (4318)	164 (4166)	
	10		Lift Height (Preferred Triple Stage)	in(mm)	189 (4800)	189 (4800)	
	11		Free Lift, Triple Stage	in(mm)	58.5 (1486)	57.9 (1471)	
	12	Upright Tilt	Back/Forward, (See Tilt Specifications)	deg	5/6	5/6	
	14	Fork	Std. Fork Size (T X W X L)	in(mm)	1.75x5x42 (45X125X1067)	2x5x42 (50X125X1067)	
	15	Overall Dimensions	Length to Fork Face	in(mm)	87.7 (2228)	92.2 (2342)	
	16		Width (Std. Tires) ³	in(mm)	43.9 (1114)	45.4 (1154)	
	17		Height, Upright Lowered	in(mm)	88 (2235)	88 (2235)	
	18		Height, Upright Extended (LBR)	in(mm)	237 (6020)	237 (6020)	
	19	Turning Radius	Outside	in(mm)	73.9 (1877)	78.3 (1989)	
	20	Load Center Distance	Center of Drive Axle to Fork Face	in(mm)	16.9 (429)	17.5 (445)	
	22	Right Angle Stack Aisle	Add Load Length and Clearance	in(mm)	91.3 (2319)	96.2 (2444)	
	Performance ²	23	Stability	According to ANSI		Yes	Yes
		24	Travel Speeds, Loaded	With Max Load	mph (km/h)	8.2 (13.2) 9.8 (15.8)	7.5 (12.1) 9.4 (15.1)
25		Travel Speeds, Empty	With No Load	mph (km/h)	8.7 (14.0) 10.8 (17.4)	8.0 (12.9) 10.4 (16.7)	
26		Lift Speeds, Loaded	Triple Stage	fpm (m/s)	49 (0.25) 82 (0.42)	45 (0.23) 80 (0.41)	
		Lift Speeds, Empty	Triple Stage	fpm (m/s)	84 (0.43) 104 (0.53)	84 (0.43) 104 (0.53)	
27		Lower Speeds, Loaded	Triple Stage	fpm (m/s)	92 (0.47)	92 (0.47)	
		Lower Speeds, Empty	Triple Stage	fpm (m/s)	80 (0.41)	80 (0.41)	
Weights ²	34	Service Weight	Min Battery Weight, 30.5 in compartment	lb(kg)	11155 (5060)	11828 (5365)	
	35	Axle Loading	With Load, Front	lb(kg)	15181 (6886)	16219 (7357)	
			With Load, Rear	lb(kg)	1975 (896)	2108 (956)	
	36		W/O Load, Front	lb(kg)	4594 (2084)	5027 (2280)	
	37		W/O Load, Rear	lb(kg)	6561 (2976)	6801 (3085)	
Chassis	39	Tires	Number, Front/Rear		2/2	2/2	
	40		Size, Front	in(mm)	21X8X15 (533x203x381)	21X9X15 (533x229x381)	
			Size, Rear	in(mm)	16X6X10.5 (406x152x267)	16X6X10.5 (406x152x267)	
	41	Wheelbase		in(mm)	53 (1346)	57 (1448)	
	42	Track	Front Cushion	in(mm)	35.8 (909)	36.5 (927)	
	43		Rear Cushion	in(mm)	34.2 (869)	34.2 (869)	
	44	Ground Clearance	Min. w/o Load	in(mm)	2.8 (71)	2.8 (71)	
	45		At Center of Wheelbase	in(mm)	4.5 (114)	4.5 (114)	
	46	Brakes	Service		Drum and Shoe	Drum and Shoe	
	47		Parking		Pedal Actuated	Pedal Actuated	
	Steering			Hydrostatic	Hydrostatic		
Drive Line	48	Battery	Type		Lead-acid	Lead-acid	
			Max Capacity (6hr. Rate) 30.5 in comp	kwh	41.8	48.6 ⁴	
			Weight, Min	lb(kg)	2600 (1180)	3100 (1407)	
	49	Motors, Controls	Drive Motor, Diameter	in(mm)	10.6 (270)	10.6 (270)	
	50		Hydraulic Motor, Diameter	in(mm)	7.9 (200)	7.9 (200)	
	51		Drive Motor Control		Mosfet Inverter	Mosfet Inverter	
	52		Speed Control		Solid State	Solid State	
	53		Hydraulic Motor Control		Mosfet Inverter	Mosfet Inverter	
	54						
	55						
	57	Hydraulic Pressure	For Attachments	psi(bar)	Adjustable	Adjustable	
		Grade Clearance (D%)		(%)	39%	39%	

Notes: 1 See Upright Table.

2 Specifications are given with Triple Stage upright, standard battery compartment size and minimum battery weight

3 OAW with wide drive tires is 48.7 for all models; required with all quad uprights and with triple uprights above 240 inches.

4 Standard compartment size on ECX 32 model is 34.5" (876 mm).

The CLARK ECX 20/32 Series cushion tire, 100% AC electric lift truck is designed for the most demanding distribution and manufacturing applications. Its sleek, attractive styling make this workhorse aesthetically pleasing and comfortable to operate yet still maintains the muscle and durability to get the job done. To accomplish this, the ECX has incorporated many of the popular features from our successful heart of the line internal combustion trucks.

Operator Comfort / Convenience

- **Low 18.1", non-skid steps - both sides**
- **Grab handles - both sides**
- **Hydrostatic power steering**
- **Foot applied, hand released parking brake**
- **Rubber, silent block steer axle mounts**
- **Silent upright staging**
- **High visibility uprights**
- **Offset steering wheel and cowl mounted levers positioned comfortably at shoulder width**
- **Dash display with operating and diagnostic information**
- **Tilttable steering pylon**
- **Parking brake reminder**

The comfortable operator compartment allows easy entry and exit, assisted by non-skid steps and grab handles on both sides. The low cowl, high visibility upright and longitudinal overhead guard bars combine to provide optimum visibility. The ECX is equipped with the CLARK safety seat, seat belt, seat belt reminder and battery restraint system. A parking brake reminder alerts the operator to set the brake when leaving the truck.

Hydraulic levers are conveniently located on the cowl. These levers and the offset 13.75" diameter steering wheel are strategically located relative to the operator's seated position for increased comfort. A visual dash display provides a ten-segment battery status indicator and hour meter plus operational and diagnostic codes in both text and numeric form. Once properly set, the lift interrupt circuit helps protect the battery by disabling lift when the battery is approximately 80% discharged.

The rounded body design reduces sharp edges and corners for operator comfort and safety. Silent upright staging and rubber silent block steer axle mounts combine to provide smoother, quieter operation.

AC Motors

- **100% AC system**
- **All motors are totally enclosed**
- **High torque drive motors provide high draw bar pull and gradeability**

All motors used on the ECX are brushless induction motors. By eliminating brushes, CLARK has made brush changes and turning of commutators unnecessary. All motors are totally enclosed to seal out contaminants and are equipped with a temperature monitoring device that signals the control to cut back power if motor temperatures approach their limit. Encoders that provide accurate speed feedback to the control are standard on all motors. The heavy-duty drive motor produces outstanding draw bar pull allowing the ECX to ascend grades that were once only negotiable by internal combustion trucks.

Electrical Controls

- **AC Traction and Pump Controls**
- **Drive system stall warning**
- **Three forms of regenerative braking: accelerator pedal release, brake pedal actuation and reversing of the directional lever**
- **Ramp start and controlled roll-back features**
- **Accurate speed control**
- **High acceleration rates and rapid reversal of direction possible**
- **Fully adjustable to meet your specific needs**
- **Advanced thermal protection system**
- **High operating efficiency**

Every ECX comes standard with a hydraulic pump control and fully proportional lift. The pump motor only spins as fast as the operator requests, reducing energy consumption. All controls are sealed so they are

environmentally protected and frame mounted high off the ground behind the counterweight for protection. The controls have low audible noise, improved acceleration and increased operating time per battery charge. Forward, reverse and bypass (1A) contactors are eliminated, reducing maintenance. The standard motor encoder allows vehicle speed to be accurately regulated even under varying load and operating conditions. Three forms of regenerative braking return energy to the battery. Self diagnostic capabilities of the control and storage of status codes aid trouble shooting and minimize downtime.

Drive Line

- **Quiet, helical gear construction**
- **Automotive drum and shoe brakes**
- **Axle housing supports upright on large trunion mounts**

"Plug-in" drive motor design mates the splined armature shaft directly to the axle assembly for positive alignment and improved heat dissipation. Helical drive gears provide smooth, quiet operation.

Brakes can be easily accessed without upright removal. The responsive single-stage master cylinder allows low and consistent pedal effort. Brakes are quiet and feature an industrial-grade self adjuster. Foot actuated, hand released parking brake offers reduced effort operation and incorporates independent cables which engage the service brakes.

Hydraulic System

- **Adjustable flow regulation**
- **Built-in port for pressure checks**
- **Single auxiliary valve is standard**
- **Continuous fluid filtration**
- **O-ring face seals reduce leaks, simplify service**

Continuous fluid filtration achieves high filtering efficiency with a 10 micron return line filter and a 100 mesh suction strainer. Hydraulic cushioning contributes to smoother operation by eliminating harsh upright staging. Tilt cylinder design allows in-truck packing replacement.

Steering

- **Full hydrostatic power steering**
- **Compact axle design with integral, double acting steer cylinder**

Spindle assemblies with king pins and tapered roller bearings provide rugged, easily serviced assemblies. Rubber, silent block mounts support the axle, absorb shock and reduce noise and vibration. Metal shields protect bearing seals from string and other debris while grease fittings extend linkage, king pin and bearing service life.

Uprights

- **High visibility two, three and four stage uprights**
- **All roller construction reduces friction and energy consumption**
- **C-channel outer rails and I-section inner and intermediate rails increase strength and rigidity**

Upright and carriage rollers are canted to handle normal as well as side thrust loads. ITA class II and III carriages incorporate six main rollers, adjustable side thrust rollers and tapered fork bars for improved visibility.

The load backrest design provides optimum visibility and the mounting bolts are offset to prevent load and rack damage. A Hydraulic tilt lock valve prevents improper tilt cylinder operation, integral flow limiting valves prevent rapid carriage descent in the event of a line failure and lowering control allows faster lowering speeds when empty or with light loads.

Standard Features

Overhead guard, 48 in. load backrest, single auxiliary valve, cowl mounted hydraulic levers, electric horn and adjustable seat. High visibility CLARK green finish with non glare black trim and bright white wheels. Operator manual, data plate and service information labels are permanently affixed to truck. CLARK's *Employer's Guide to Material Handling Safety* and operator safety video are provided with each truck.