

CRXFL

10 | 13 | 14 | 15 | 18 | 20 | 25

ELECTRIC REACH TRUCK 24/48 VOLT
1000 - 2500 kg
2000 - 5000 lbs.



CLARK®

THE FORKLIFT

OPTIMUM COMFORT & ERGONOMICS



Spacious Operator Compartment

The wider entrance and compartment space provides a comfortable and safe work environment.



Brake Oil Reservoir

Easily accessible and protected by an external cover. The brake oil reservoir is conveniently located on the cowl allowing for quick and easy checking.



High Sensitivity Levers

The sensitive control levers minimise fatigue over longer operating hours and the ease of adjustment enhances work efficiency.



Cold Storage Key Switch

Fitted as standard, the key switch is water and vibration proof which makes it suitable to operate in cold storage applications.



Emergency Stop Button

When faced with the risk of injury, the operator is able to quickly access the stop button and ensure their own safety and that of others within the vicinity.



Smooth Handling

The shorter diameter steering wheel has a molded type knob which gives greater control and accuracy of the machine whilst reducing operator fatigue.



Adjustable Body Cushion

Height control function allows customisation of the waist rest to suit individual preference.



LCD Monitor

It is easy to monitor the performance of the CRXFL and stay at optimal operation with the LCD monitor providing varying coloured notifications to the operator. The LCD monitor makes it easy to adjust acceleration and maximum speed.

CRXFL

Ergonomic operator compartment provides ease of access to all controls with the comfort of a modern interior design.



Maintenance is made easy with convenient access. This reduces the downtime of the CRXFL and helps maximise durability.



Best performance!

Best choice!

CLARK *CRXFL*

Electric forklift series



Easy Access to Battery

Makes battery maintenance and checking on distilled water easy.



Brake System

Brake pad, disc adjustment device, cam return and linkage change enhances the brake performance. Brake response minimises the driver fatigue.



Battery Installation

Use foot pedal and accelerator at the same time to access the battery.



Anti-roll Down Function

When no longer accelerating the electric brake is automatically engaged. By virtue of anti-roll down function the CRXFL is held stationary - even if stopped on a hill.



Improved Accessibility

Various electric parts including the controller are installed behind an easy access panel.

Strong and powerful with upgraded economy!



Powerful German AC motor made by Schabmuller



Italian Controller made by ZAPI

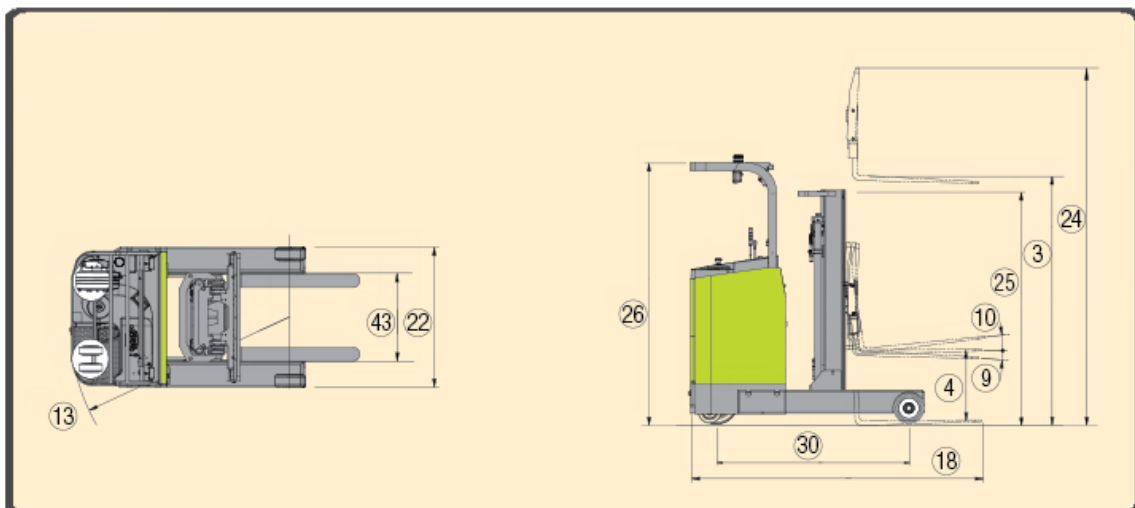

● GENERAL SPECIFICATIONS

Model			Unit	CRX10FL	CRX13FL	CRX14FL	CRX15FL	CRX18FL	CRX20FL	CRX25FL	
Performance	1	Load capacity	kg	1000	1250	1350	1500	1750	2000	2500	
	2	Load centre	mm	500	500	500	500	500	500	500	
	3	Max. lift height	mm	3000	3000	3000	3000	3000	3000	3000	
	4	Free lift height	mm	405	405	405	405	410	415	415	
	5	Lifting speed	Loaded	mm/sec	250	220	350	340	300	260	230
	6		Unloaded	mm/sec	400	400	460	460	460	400	400
	7	Lowering speed	Loaded	mm/sec	530	530	530	530	530	500	500
	8		Unloaded	mm/sec	440	440	440	440	440	440	440
	9	Tilt angle	Forward	deg.	3	3	3	3	3	3	3
	10		Backward	deg.	5	5	5	5	5	5	5
	11	Travel speed	Loaded	km/h	9.6	9.6	10.4	10.4	10.4	10.2	10.2
	12		Unloaded	km/h	9.8	9.8	10.4	10.4	10.4	10.4	10.4
	13	Turning radius (outside)	mm	1336	1480	1512	1608	1754	1779	1972	
	14	Right angle stacking width	mm	2500	2532	2655	2676	2720	2796	2869	
	15	Reach Stroke (2stage/LOW/3stage)	mm	430/-/385	580/-/530	490/460/430	590/550/530	730/-/630	630/-/540	825/795/740	
	16	Gradeability (Reach In)	Loaded	%	19.1	19.1	19.1	19.1	19.1	10	10
	17		Unloaded	%	30	30	30.2	30.2	30.2	23.6	23.4
Dimensions	18	Length (With fork) (Reach out)	2stage	mm	2401	2551	2615	2715	2855	3000	3195
	19		3stage	mm	2409	2554	2604	2704	2824	2982	3182
	20	Length (With fork) (Reach in)	2stage	mm	1971	1971	2125	2125	2125	2370	2370
	21		3stage	mm	2024	2024	2174	2174	2194	2442	2442
	22	Overall width	STD	mm	1043	1043	1090	1090	1090	1184	1230
	23		TSU	mm	1080	1080	1169	1169	1169	1264	1348
	24	Mast Height	Extended	mm	3929	3929	3929	3929	3929	3970	3970
	25		Lowered	mm	1995	1995	1995	1995	1995	2050	2050
	26	Overhead guard height	mm	2259	2259	2275	2275	2275	2294	2294	
	27	Fork dimensions	mm	35x100x920				40x100x920		45x100x1070	
	28	Forward overhang (2stage/LOW/3stage)	mm	185/-/193	185/-/188	218/220/207	218/210/207	208/-/177	185/-/168	180/180/168	
29	Forward overhang w/S/S (2stage/LOW/3stage)	mm	340/-/347	340/-/342	372/374/362	372/364/362	358/-/328	339/-/322	334/334/322		
Tire	30	Wheel base	mm	1100	1250	1250	1350	1500	1500	1700	
	31	Drive wheel	-	280x135	280x135	315x145	315x145	315x145	380x165	380x165	
	32	Load wheel	-	255x120	255x120	254x114	254x114	254x114	267x114	267x135	
Other Specifications	33	Castor Wheel	-	178x73				204x76			
	34	Brake	-	Mechanical	Mechanical	Mechanical	Mechanical	Mechanical	Mechanical	Mechanical	
	35	Battery Capacity (5 hour rate)	V/ah	24/400	24/400	48/210	48/280	48/280	48/335	48/335	
	36	Battery weight	kg	350	350	425	480	480	577	577	
	37	Drive motor power	kw	4.2	4.2	8.3	8.3	8.3	8.3	8.3	
	38	Hydraulic motor power	kw	8.3	8.3	14.0	14.0	14.0	15.0	15.0	
	39	Steering motor power	kw	0.4	0.4	0.3	0.3	0.3	0.3	0.3	
	40	Control method	-	Mosfet inverter							
	41	Charger power	-	(220/380/440V)							
	42	Max. hydraulic flow for attachment	kg/cm ²	120	120	160	160	160	175	175	
	43	Max. fork width (Outer width)	2stage	mm	595	595	695	695	695	708	708
	44		3stage	mm	695	695	781	781	781	708	708
	45	Equipment weight (Reach in)	2stage	kg	1890	1906	2287	2297	2318	2793	2900
	46	No load	3stage	kg	2024	2040	2439	2449	2450	2945	3052

* Right angle stacking width: pallet 1200x1200